

# X16

## User Manual





**WARNING**  
**AVERTISSEMENT**

**ALWAYS FOLLOW SAFETY PRECAUTIONS**  
**RESPECTEZ TOUJOURS LES CONSIGNES DE SÉCURITÉ**

- Death or serious injury may occur when children climb on audio and/or video equipment furniture. A remote control or toys placed on the furnishing may encourage a child to climb on the furnishing and as a result the furnishing may tip over on to the child.
- Relocating audio and/or video equipment to furniture not specifically designed to support audio and/or video equipment may result in death or serious injury due to the furnishing collapsing or over turning onto a child.
- Il y a un danger de blessures graves ou même de mort si un enfant grimpe sur un meuble pour matériels audio ou vidéo. Une télécommande ou un jouet laissés sur le meuble peuvent inciter l'enfant à y grimper, ce qui peut provoquer le basculement du meuble sur l'enfant.
- Le repositionnement de matériels audio ou vidéo sur un meuble non spécialement conçu pour cela peut causer la mort ou des blessures graves par effondrement ou renversement du meuble sur un enfant.

Secure the cabinet  
to avoid fall down.

Sécurisez l'armoire pour  
éviter qu'elle soit tombée.

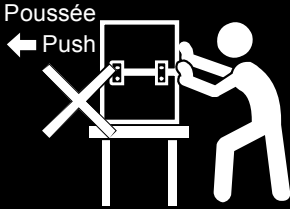

Only Adults should  
move the cabinet.

L'armoire ne doit être  
déplacé QUE PAR DES  
ADULTES.



Never climb, sit or  
stand on the cabinet.

Personne ne doit s'asseoir,  
se tenir ou grimper sur  
armoire.



### **⚠ CAUTION**

This cabinet is intended for use only with loading as indicated. Use with loads greater than indicated may result in instability causing possible injury.

### **⚠ MISE EN GARDE**

Ce armoire est conçu pour n'être  
utilisé qu'avec des charges telles  
qu'indiquées. L'utilisation avec  
des charges supérieures aux  
indiquées peut rendre armoire  
instable et causer des blessures.

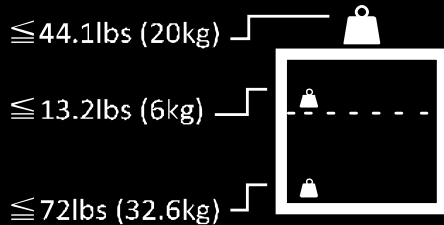

## CAUTION

- **DO NOT** allow anyone to sit, stand or climb on the cabinet.
- **DO NOT** lift the cabinet.
- **DO NOT** block the ventilation holes used for air circulation.
- **DO NOT** overload objects on the cabinet shelves. (Work platform maximum loading = 20kg / 44.1lbs; each shelf maximum loading = 32.6kg / 72lbs).
- **DO NOT** put any devices that exceed the maximum loading weight on top of cart.
- When moving the cart, **DO NOT** put any devices (e.g. TV, Monitor, Documents camera, etc.) on top of the cabinet.
- **DO NOT** use any TV/monitor/display on top of the cabinet.
- Before moving the cart, disconnect the power from the wall outlet.
- When moving the cart, make sure the power cord is firmly plugged into the socket and confirm main earth connection.
- When disconnecting the AC power cord, be absolutely sure to first disconnect the plug from the outlet socket.

## ATTENTION!

- **PERSONNE** ne doit s'asseoir, se tenir ou grimper sur armoire.
- **IL NE FAUT PAS** soulever armoire.
- **IL NE FAUT PAS** obstruer les orifices de ventilation qui permettent à l'air de circuler.
- **IL NE FAUT PAS** surcharger d'objets les étagères de l'armoire (charge maximale de la plateforme de travail : 20 kg / 44,1 lbs ; charge maximale de chaque étagère : 32,66 kg / 72 lbs).
- **IL NE FAUT PAS** poser sur le haut de l'armoire des appareils dont le poids dépasse la charge maximale.
- Pour déplacer le chariot, **IL NE FAUT** poser aucun appareil (poste de TV, moniteur, caméra pour documents, etc.) sur le haut de l'armoire.
- N'utilisez aucun téléviseur ni moniteur sur le haut de l'armoire.
- Avant de déplacer l'armoire, débranchez la prise secteur.
- Avant de démarrer le système, assurez-vous que le cordon d'alimentation est branché adéquatement sur une prise de courant ainsi que la connexion principale de mise à la terre soit établie.
- Lors de la déconnexion du cordon d'alimentation, soyez absolument certains que la fiche a été retirée de la prise de courant.

## **FCC NOTICE (Class A)**



This device complies with Part 15 of the FCC Rules. Operation is subject to the following two conditions: (1) this device may not cause harmful interference, and (2) this device must accept any interference received, including interference that may cause undesired operation.

### **Federal Communications Commission Statement**

NOTE: This equipment has been tested and found to comply with the limits for a Class A digital device, pursuant to part 15 of the FCC Rules. These limits are designed to provide reasonable protection against harmful interference when the equipment is operated in a commercial environment. This equipment generates, uses, and can radiate radiofrequency energy and, if not installed and used in accordance with the instruction manual, may cause harmful interference to radio communications. Operation of this equipment in a residential area is likely to cause harmful interference in which case the user will be required to correct the interference at his own expense.

**FCC Caution:** Any changes or modifications not expressly approved by the party responsible for compliance could void the user's authority to operate this equipment.

This device complies with part 15 of the FCC Rules.

Operation is subject to the following two conditions:

- (1) This device may not cause harmful interference, and
- (2) this device must accept any interference received, including interference that may cause undesired operation.

### **DISCLAIMER**

No warranty or representation, either expressed or implied, is made with respect to the contents of this documentation, its quality, performance, merchantability, or fitness for a particular purpose. Information presented in this documentation has been carefully checked for reliability; however, no responsibility is assumed for inaccuracies. The information contained in this documentation is subject to change without notice.

In no event will AVer Information Inc. be liable for direct, indirect, special, incidental, or consequential damages arising out of the use or inability to use this product or documentation, even if advised of the possibility of such damages.

### **TRADEMARKS**

"AVer" is a trademark owned by AVer Information Inc. Other trademarks used herein for description purpose only belong to each of their companies.



## COPYRIGHT

©2020 AVer Information Inc. All rights reserved.

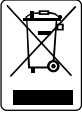
All rights of this object belong to AVer Information Inc. Reproduced or transmitted in any form or by any means without the prior written permission of AVer Information Inc. is prohibited. All information or specifications are subject to change without prior notice.



The mark of Crossed-out wheeled bin indicates that this product must not be disposed of with your other household waste. Instead, you need to dispose of the waste equipment by handing it over to a designated collection point for the recycling of waste electrical and electronic equipment. For more information about where to drop off your waste equipment for recycling, please contact your household waste disposal service or the shop where you purchased the product.

-  IEC 60417-6042 (2010-11); and  IEC 60417-6172 (2012-09)

Two individual switch power supply provided, however all primary circuits are contained within the switch power supply. No any hazardous voltage can be accessed when removing any single switch power supply.

Before running the system, make sure the power cord is firmly plugged into the socket and confirm main earth connection.

**CAUTION:** When disconnecting the AC power cord, be absolutely sure to first disconnect the plug from the outlet socket.

## Contact Information

### **USA**

AVer Information Inc.

<https://www.averusa.com>

668 Mission Ct.,

Fremont, CA 94539

Tel: +1 (408) 263 3828

Toll-free: +1 (877) 528 7824

Technical support: [support.usa@aver.com](mailto:support.usa@aver.com)

# CONTENTS

<b>Package Contents</b> .....	<b>1</b>
<b>Tools Required</b> .....	<b>1</b>
<b>Optional Accessory</b> .....	<b>2</b>
<b>Dimensions</b> .....	<b>2</b>
<b>Diagram</b> .....	<b>3</b>
Front and Back .....	3
Sides .....	3
Top and Bottom .....	4
<b>Installation</b> .....	<b>5</b>
Door/Top Cover Lock .....	5
Charging the Cabinet .....	6
Adapter Configuration .....	7
Cable Management .....	8
<b>Wall Mount</b> .....	<b>9</b>
<b>Stacking Installation</b> .....	<b>10</b>
<b>Troubleshooting</b> .....	<b>12</b>
<b>Specifications</b> .....	<b>13</b>
<b>Service and Warranty</b> .....	<b>14</b>

# Package Contents

The following items are included in the package. Please check if each item is available before using.



**User Manual**



**Concrete Anchors x6**

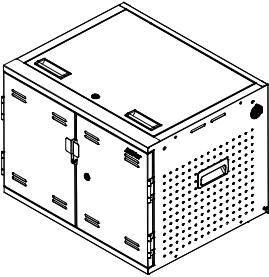

**X16 Cabinet**

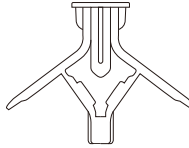

**Drywall Anchors x6**



**M5x32L Anchor**

**Screws x6**



**Keys x4**



**Washers x6**



**Cable Grommets x2**

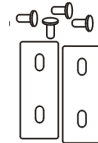

**Stacking Kit**

## Tools Required

For wall mount use.

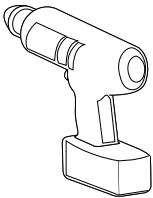

**Drill**

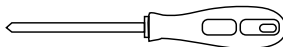

**Screwdriver**



# Optional Accessory

**Mobile Kit** (The following items are included in this kit.)

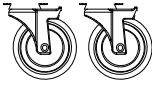

**5" Casters x2**



**5" Lockable Casters x2**



**Caster Screws x16**

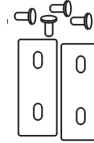

**Stacking Kits x3**

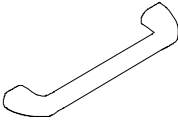

**Handle bar**



**Handle bar Screws and Washers  
x2**

## Dimensions

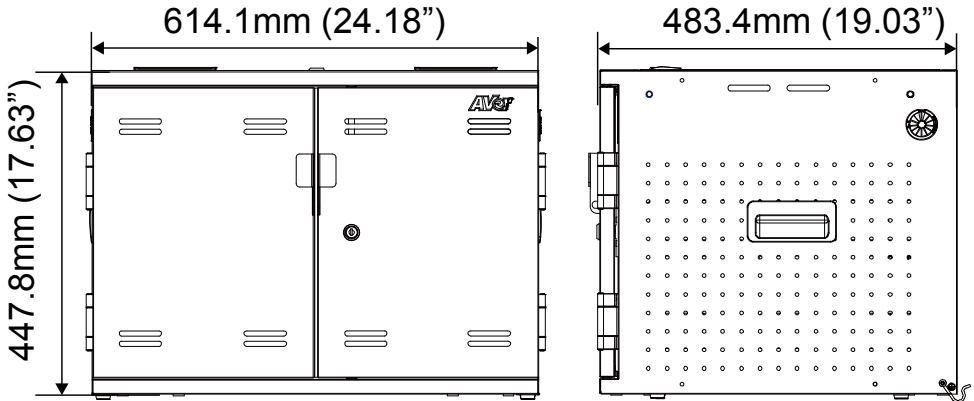

# Diagram

## Front and Back

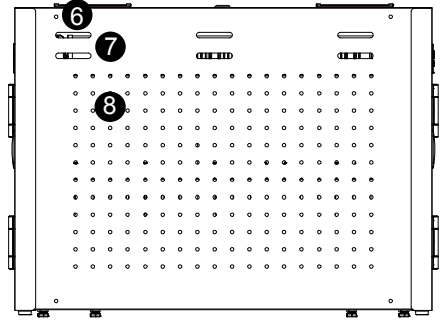
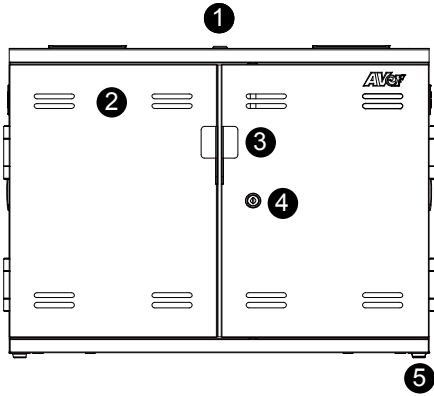

## Sides

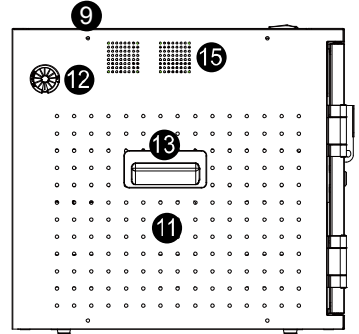
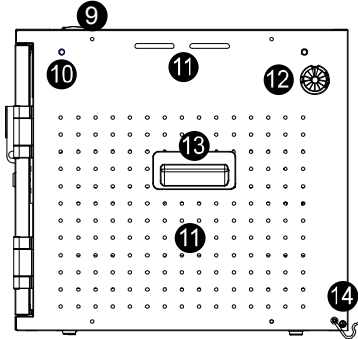

## Top and Bottom

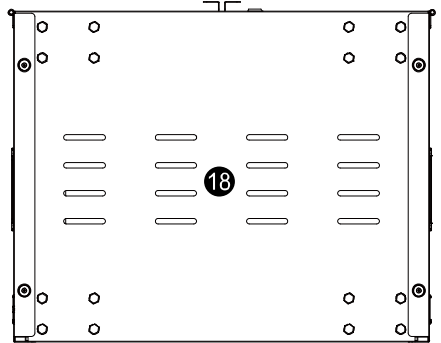
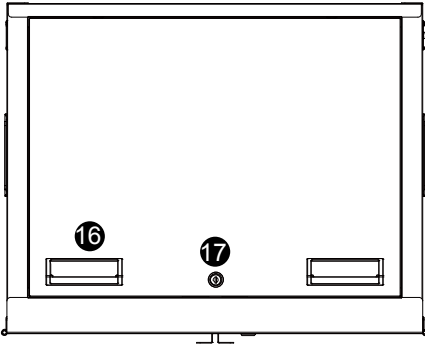

Front and Back	Sides	Top and Bottom
1. Cabinet top cover	9. Stacking holes	16. Handles
2. Ventilation holes	10. Handlebar holes	17. Top cover lock
3. Finger pull	11. Ventilation holes	18. Ventilation holes
4. Door lock	12. Power cable holes	
5. Foot rubbers	13. Handles	
6. Stacking holes	14. Earthing screw	
7. Wall mount holes	15. Smart fan holes	
8. Ventilation holes		

# Installation

## [Note]

1. It is recommended to use cable ties or zip-tie (not supplied) to secure and manage cables.
2. It is recommended to allocate 2 persons for efficient device cabling.

## Door/Top Cover Lock

For security, use the lock key to secure the door and top cover.

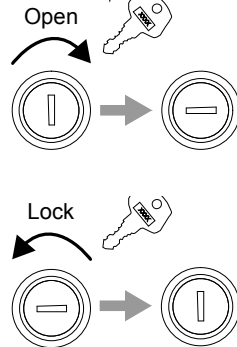
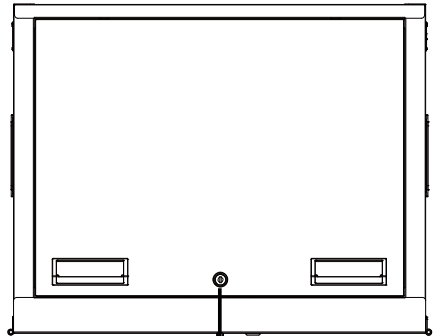
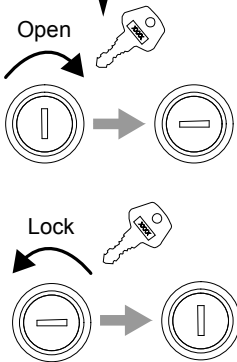
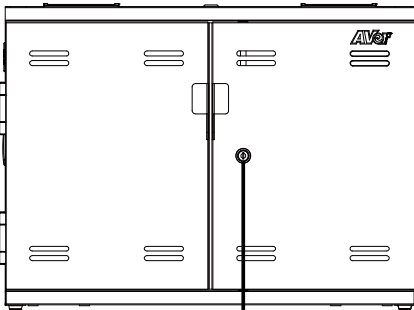

# Charging the Cabinet

1. Use the included key to open the top cover.
2. Remove the top cover and accessory package.
3. Feed the power cord through the hole space provided and place the cable grommet into the hole space provided.
4. Connect the power cord to a wall outlet.

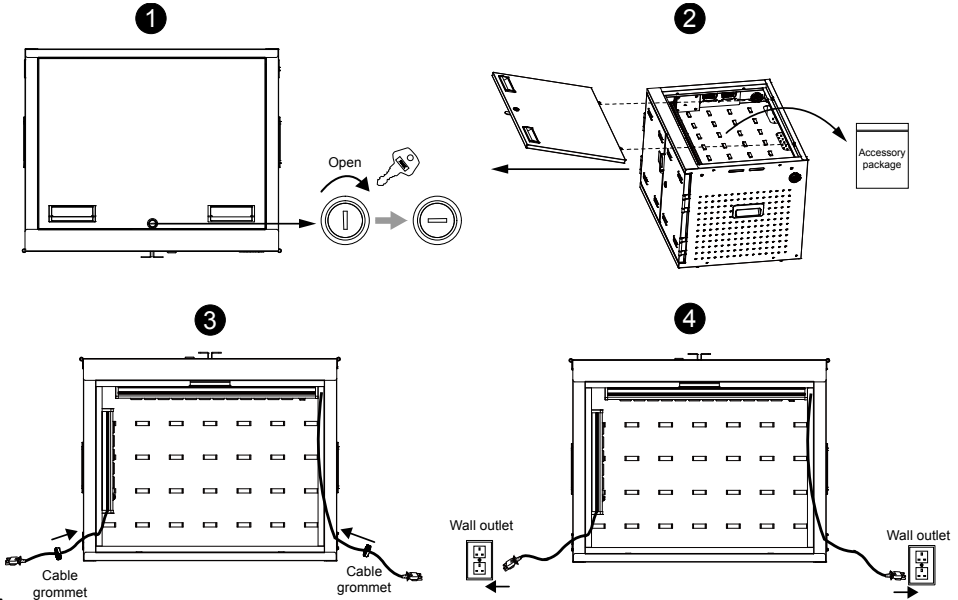

## [Notes]

1. Set the power socket to the OFF position before plugging the cabinet to wall outlet.
2. Two individual switch power supply provided, however all primary circuits are contained within the switch power supply. No any hazardous voltage can be accessed when removing any single switch power supply.
3. When disconnecting the AC power cord, be absolutely sure to first disconnect the plug from the outlet socket.
4. For the ventilation purpose, please keep at least 5cm (1.97") distance between the smart fans and the wall.

# Adapter Configuration

1. Place the power adapter onto the adapter drawer in order.  
**[Note]** Save the power AC socket closest to the smart fan for it.
2. Pass the DC-end of the adapter cable through the hole located on the back of adapter drawer.
3. Plug-in the AC-end of the adapter cable to the power AC socket.
4. Align the top cover hole to install the top cover and use the included lock key to lock it.

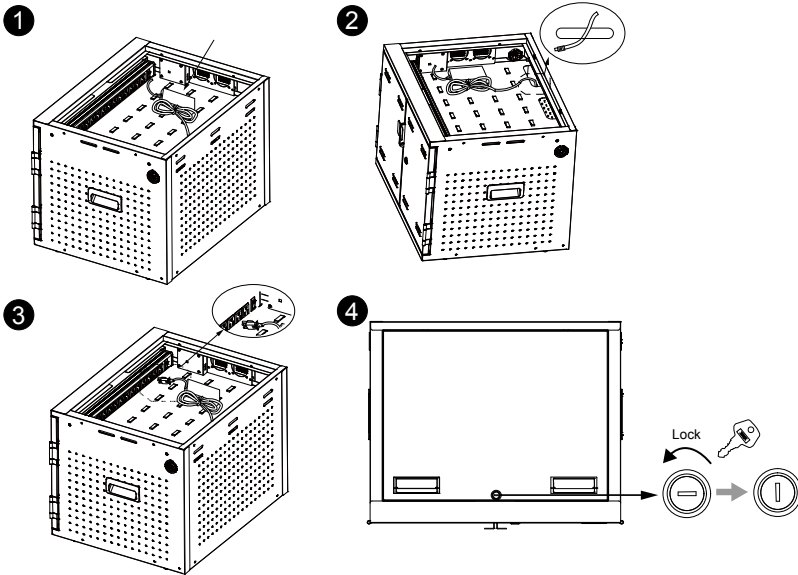

## [Notes]

1. Place the power adapter onto the adapter drawer in order; don't stack the adapters.
2. Before running the system, make sure the power cord is firmly plugged into the socket and confirm main earth connection.
3. Make sure the power plug of smart fan is plugged in. Smart fan will automatically turn on when temperature arises and turn off when temperature drops. For the ventilation purpose, please keep at least 5cm (1.97") distance between the smart fans and the wall.

## Cable Management

1. Use the included key to open the front door.
2. Route the adapter DC-end cable along with the V-shape routing groove.
3. Snap the locking piece until hearing a "click" to firmly secure the DC-end cable.  
**Remember to reserve enough length of power cable to connect the power plug of the device.**
4. Place the mobile device into the bay and plug in the DC-connector to the mobile device.

1

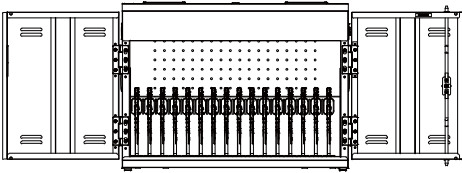

2

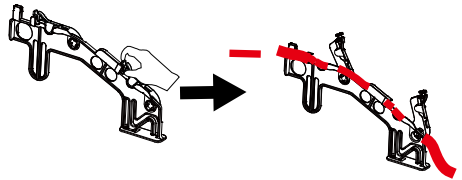

3

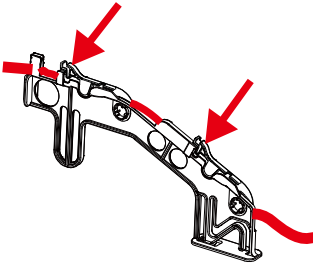

4

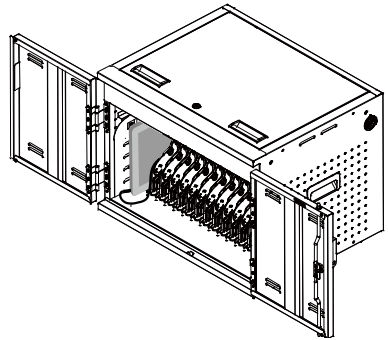

# Wall Mount

1. Open the top cover.
2. There are 6 mount holes on the cabinet's rear panel. (See below figure for exact mount holes locations).

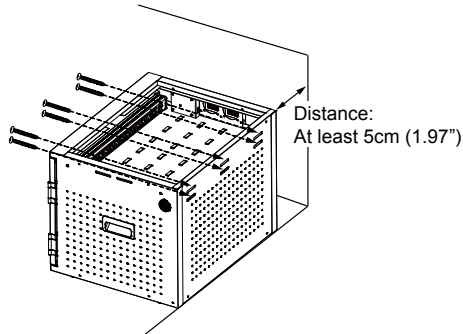

3. Secure the cabinet to the wall studs for drywall mounting. Drill the holes at the wall studs through the drywall, and firmly tap the drywall anchors in until they are flush with the wall.

**[Note]** For the ventilation purpose, please keep at least 5cm (1.97") distance between the smart fans and the wall.

4. For concrete wall mounting, please use concrete wall anchors and fully flush the anchors to the drilled holes.
5. Secure the cabinet to the wall with provided anchor screws (with washers).
6. Close the top cover and lock it with key.

**[Note]** The cabinet must be installed by a qualified technician. Use suitable mounting means when installing to cinder block, concrete or drywall.



# Stacking Installation

## With Stacking Kit

The X16 cabinets can use the included stacking kit to stack cabinets and secure them together. The stacking installation is illustrated below:

**[Note]** The maximum stack is 2 cabinets.

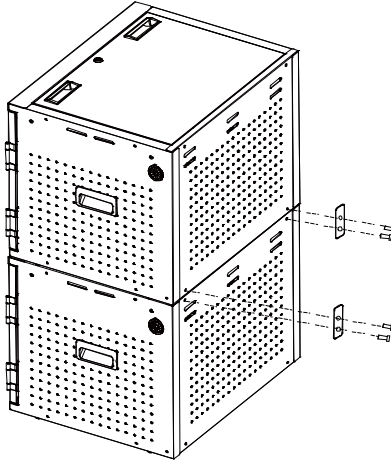

## With Mobile Kit (Optional)

1. Use screws to attach four casters to the base of one cabinet. Lockable casters should be installed on the same side with the handle bar holes to allow easy access.
2. Remove two handle caps out of the handle bar. Use washers and screws to attach the handle bar to another cabinet, using Allen wrench to screw the handle bar.
3. Place the cabinet with the handle on the top of the cabinet with the casters.
4. Use the included stacking kits to secure the cabinets together.

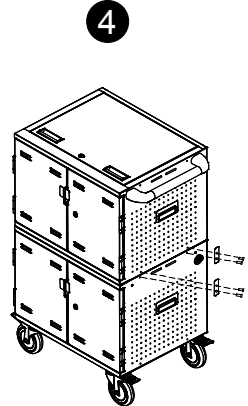
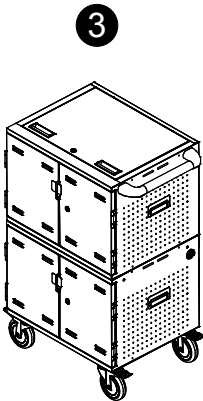
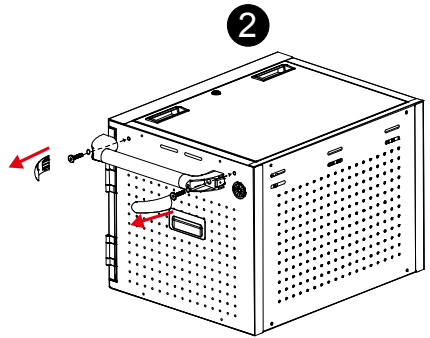
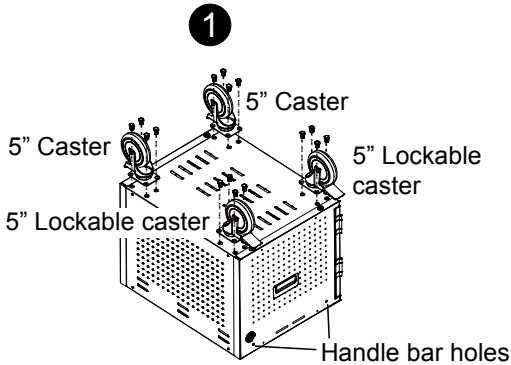

# Troubleshooting

**Q: Why are all of my devices plugged in but not charging?**

- A: 1. Make sure power cords are undamaged.
2. Make sure power cords are firmly inserted into the available socket with stable current.
  3. Make sure the power plug and current consumption are compliant with your country specification standards.

**Q: My cabinet's main power cord or cabinet components are damaged. Are they covered under warranty?**

A: We provide a 10 years warranty on the cabinet and main frame, and 5 years warranty on the electrical components.

**Q: How do I know if my devices will exceed more than the allotted current?**

A: Have a qualified electrician verify the current consumption of your devices. Perform the test with devices installed and batteries discharged.

**Q: When I plug in the device, it trips the circuit breaker. What is wrong?**

A: You may have other equipment or appliances sharing the same circuit that is causing a circuit overload. Have a qualified electrician check that adequate power is available in the circuit.

# Specifications

<b>Model</b>	X16
<b>Capacity</b>	16
<b>Supported Devices</b>	Mobile devices up to 15"
<b>Charging Type</b>	AC/ Fully Charging
<b>Power Specification</b>	Power Strip: 100-120V ~ 50/60Hz, 12A
<b>Security</b>	<p><b>Front door:</b> 2 points mechanism with key lock function. Padlock hole is combined with handle.</p> <p><b>Top cover:</b> 1 point key lock function.</p> <p>The key of front door and top cover use the same key.</p> <p><b>[Note]</b> Padlock is not included in the package.</p>
<b>Smart Fan Control</b>	Yes
<b>Fixed Shelf</b>	Yes
<b>Top Surface (Work Platform)</b>	20kg (44.1lbs)
<b>Shelf Support Weight (ea.)</b>	32.66kg (72lbs)
<b>Adapter Shelves (ea.)</b>	6kg (13.2lbs)
<b>Working Temperature</b>	0°C ~30°C
<b>Working RH%</b>	10%~90%
<b>Storage Temperature</b>	-40°C~60°C
<b>Storage RH%</b>	5%~95%
<b>Warranty</b>	<p>10 years cabinet and tray</p> <p>5 years electrical components</p>
<b>Cabinet Dimensions (W x D x H)</b>	<p>614.1 × 483.4 × 447.8 mm</p> <p>(24.18" × 19.03" × 17.63")</p>
<b>Slot Dimensions (W x D x H)</b>	<p>26 × 419.1 × 304.8 mm</p> <p>(1.02" × 16.5" × 12")</p>
<b>Weight without Devices</b>	26.1kg (57.54lbs) ± 2kg(4.41lbs)

## **Service and Warranty**

All of our products come with a quality and safety assurance.

For customers located in North America, please visit the AVer USA support site for comprehensive RMA, Warranty, and Service information:

<https://www.averusa.com/classroom-technology/support/>

## Appendix – Earthing

### [Caution]

High touch current, Connect to earth before connecting to supply.

(Yellow/Green wire min. 14AWG)

### [Note]

Installation of the protective earthing connection of the socket-outlet by a skilled person.

### [Attention]

Contact à courant élevé,

Reliez l'appareil à la terre avant de la connexion à l'alimentation en courant.

(Câble jaune/vert min. 14AWG)

### [Remarque]

L'installation du branchement de mise à la terre sécurisée d'une prise de courant par un professionnel qualifié.

